

ISIMET

Utility Controller

Series 1000 / 2000 / 3000 / 4000



**Version 9.1
Installation,
Maintenance,
Operations,
and Start-up
Instructions**



ISIMET Utility Controller
Installation, Maintenance, Operations, and Startup Instructions

Copyright © 2015 **ISIMET/MAPA, LLC**.

All rights reserved.

Patent 6,757,589 B1, 6,990,393 B2, 8,543,225, Other Patents Pending

This document is copyrighted. This document may not, in whole or part, be copied, duplicated, reproduced, translated, electronically stored, or reduced to machine readable form without prior written consent from **ISIMET**.

Although the material contained herein has been carefully reviewed, **ISIMET** does not warrant it to be free of errors or omissions. **ISIMET** reserves the right to make corrections, updates, revisions, or changes to the information contained herein.

ISIMET is a trademark of **ISIMET/MAPA, LLC**, an affiliate of **WCM Industries, Inc.**

Warranty:

ISIMET will repair or replace any defective parts or workmanship of the product for a period of one year from date of installation. The Primary Operating P.C. Board has a two year limited warranty. Damage caused by incorrect installation or improper usage is not warranted. Failure to follow recommended installation, operation, and/or maintenance procedures may void product warranty. Recovery rights shall be limited to the total sum of the amounts paid for the product by the purchaser.

Limits of Liability:

ISIMET's liability shall be limited to costs of repair or replacement parts. The Laboratory Service Panel and Utility Controller Systems are not intended for usage other than those expressly described in the provided manuals for each product. **ISIMET** shall not be liable for damage or injury caused by the improper use of the product.

ISIMET does not warrant against or assume liability for failure of operation or lack of notification to secondary integrated monitoring systems. The system should be thoroughly tested and adjustments made at time of initial operation. Periodic testing should be conducted by the user to assure that all components function and operate according to specifications.

Care should be taken in the installation of this product. **ISIMET** shall not be liable for damage or injury caused from the improper installation of the product.

Warranty is Subject to Compliance with Specific Installation Requirements.

EXTENDED WARRANTY:

ISIMET will extend the warranty period of the products when installation complies with all start up procedures and that a factory authorized agent either performs or is in attendance during start-up of the system(s). Controllers, Companion and Accessory Panels will be extended to a period of five years from date of installation. Except for **ISIMET** FLA, DLA, RLA and other Units where automation systems are not common, Control System(s) must be interfaced with a building automation system or other **ISIMET** approved time sequencing control for "non-use" system shutdown. All operating components of the system must be **ISIMET** provided. Prescribed routine maintenance procedures must be performed per **ISIMET** recommendations.

All Start-up and Routine Maintenance Documentation shall be per Factory Recommendation.

Further, required start-up and maintenance procedures must be performed as directed upon all affected systems. This warranty shall only become enforceable upon issuance of application specific Extended Warranty Document. A copy of this document should be maintained at all times at the location of the warranted systems.

DISCLAIMER OF IMPLIED WARRANTY:

THERE ARE NO WARRANTIES THAT EXTEND BEYOND THE DESCRIPTION HEREIN. SELLER DISCLAIMS ANY IMPLIED WARRANTY OF MERCHANTABILITY OF THE GOODS OR OF THE FITNESS OF THE GOODS FOR ANY PURPOSE, AND BUYER AGREES THAT THE GOODS ARE SOLD "AS IS."

Printed in the United States of America.

Table of Contents:

	Page
Warranty.....	2
General Product Information.....	4
Assembly, Compliance and Registration Information.....	4
Pre-Installation Information.....	4
Electrical Specifications.....	5
Model Number Description.....	5
Utility Controller Illustration and Parts List.....	6
Fuse Specifications.....	6
Door and Control Panel Illustration and Parts List.....	7
Installing the Utility Controller.....	8
Installing the Electrical Conduit.....	9
Wiring the Utility Controller.....	9
Connecting Controlled Utility Services.....	10
Connecting "EMS".....	10
PC Board LED Indicator Chart.....	11
Connecting Alarm and Monitoring Wiring.....	11
Connecting Optional Components, ADD-On Modules.....	11
Installing the Door Panel.....	12
Installing Flush Door Trim.....	13
Door Panel Plug.....	13
Removing and Replacing the Printed Circuit Board.....	13
Start-Up Checklist.....	14
Start-Up Test Preliminary Information.....	14
Start-Up Tests.....	15
Equipment Operation.....	16
Troubleshooting.....	17
Equipment Maintenance.....	18
Jumper Configuration.....	19
Optional Input/Output Configuration.....	20
Changing Programmable Configurations.....	21
Resetting Unit to Factory Defaults.....	22
Typical Installation Configurations.....	23

Table of Figures and Reference Tables:

	Page
Figure 1 - Model Numbers.....	5
Figure 2 - Utility Controller.....	6
Figure 3 - Door Panel.....	7
Figure 4 - Control Panel.....	7
Figure 5 - Flush Mounted Controller.....	8
Figure 6 - Surface Mounted Controller.....	8
Figure 7 - Controller Knock-Out Holes.....	9
Figure 8 - Junction Box.....	9
Figure 9 - Door Panel Installation.....	12
Figure 10 - Door Trim Installation.....	13
Figure 11 - Printed Circuit Board.....	13
Figure 12 - PC Board Jumper Configurations.....	19
Figure 13 - Terminal # 1 Pin Configuration.....	20
Figure 14 - Typical Installation Wiring Diagram.....	23
Table 1 - Programmable Inputs.....	21
Table 2 - Circuit Function Criteria.....	22

General Product Information

The Utility Controller is a safety device that grants local, absolute authority to the instructor to determine those utilities that are to be used during the class-day for experiment while restricting unauthorized student use of laboratory devices. The device regulates the control of various utility services such as domestic water, natural gas, and electrical outlets within a science classroom. A keyed switch provides for security against unauthorized use of the system.

Construction

All electrical components are pre-assembled, wired, and mounted. The Electronic Controller is assembled within the Utility Controller compartment.

The Utility Controller has either a brushed stainless steel or powder coat finish. All panels and enclosures are constructed of welded 16-gauge sheet metal.

Caution: Do not drop this assembly or expose it to the environment.

Assembly, Compliance and Registration Information

All Controllers are assembled to permit limited field configurations of the operating system. A configuration information page is included in this manual. Options requiring additional instructions and/or assembly parts are shipped within the component package. Refer to Equipment Specifications to verify that ALL components conform to these requirements.

The output circuits of the Controller provides 24 VAC control signals to solenoids and relays to activate and engage the various utilities. *ISIMET* provides a full line of Companion Enclosures and fittings. It is recommended that these items be included in the system design, but when the installer elects to provide these fittings from other sources, compliance with product specifications must be confirmed prior to installation.

Enclosed with this Manual is a separate registration form. The front of the form is for equipment warranty registration. The back is a copy of the equipment start-up checklist. To ensure proper warranty of the product, it is important that you complete both sides of the form and either mail or fax to *ISIMET* within 30 days of installation and start-up.

Pre-Installation Information

The Utility Controller assembly includes two components: the Controller and the Door Panel. The Controller is provided with a protective cover over the door opening to insure that during the construction phases of the facility that no debris enters the enclosure. A second wrap protects the PCB. Care should be taken to assure that neither is removed until final assembly and testing.

Locating and Positioning the Controller

Prior to installation, verify ADA (Americans with Disabilities Act) dimensions and compliance requirements. For best results: Install the Controller in the room where the utility services are controlled, at or near an exit, and accessible to occupants of the room. Mount the vertical center of the service switches on the door panel to the ADA-required maximum height.

The Door Panel and Trim Kit

The Door Panel and Trim Kit are packaged separately from the Utility Controller enclosure and have a protective wrapping. See Page 12 and 13 for installation instructions. (Trim Kit not provided with surface mounted units.) The provided trim kit is either flush or semi-recessed. Verify installation requirements prior to installation of the unit. Store the Door Panel and Trim Kit in a protected location, out of the weather, until installation.

Install the Door Panel onto the Utility Controller after ALL other wiring connections within the controller have been made.

Upon Receipt of Product

Each Utility Controller is assembled specifically for an individual application. All primary components have the same code number.

Check components for damage. Notify *ISIMET* immediately of any damaged components. Check package and product name plates to determine if all components were shipped correctly. Store uninstalled components in a protected environment, out of the weather.

Series 1000 / 2000 / 3000 / 4000 Intended Use:

The 1000 and 2000 Series are intended for uses where *ISIMET* provides the solenoid valves and other companion components required for the installation. The 3000 and 4000 Series are intended for uses where the installer provides the solenoid valves from sources other than *ISIMET* or where application demand requires output amperes greater than available in our standard series.

The final determination of compliance with *ISIMET* product specifications pertaining to total output load restrictions remains the responsibility of the installer.

Electrical Specifications:

Model #	Transformer	Max. Amperes	Max per Circuit
Series 1000 / 2000	3 amp	3 amp	1.5 amp
Series 3000 / 4000	4 amp	4 amp	2 amp

Figure 1

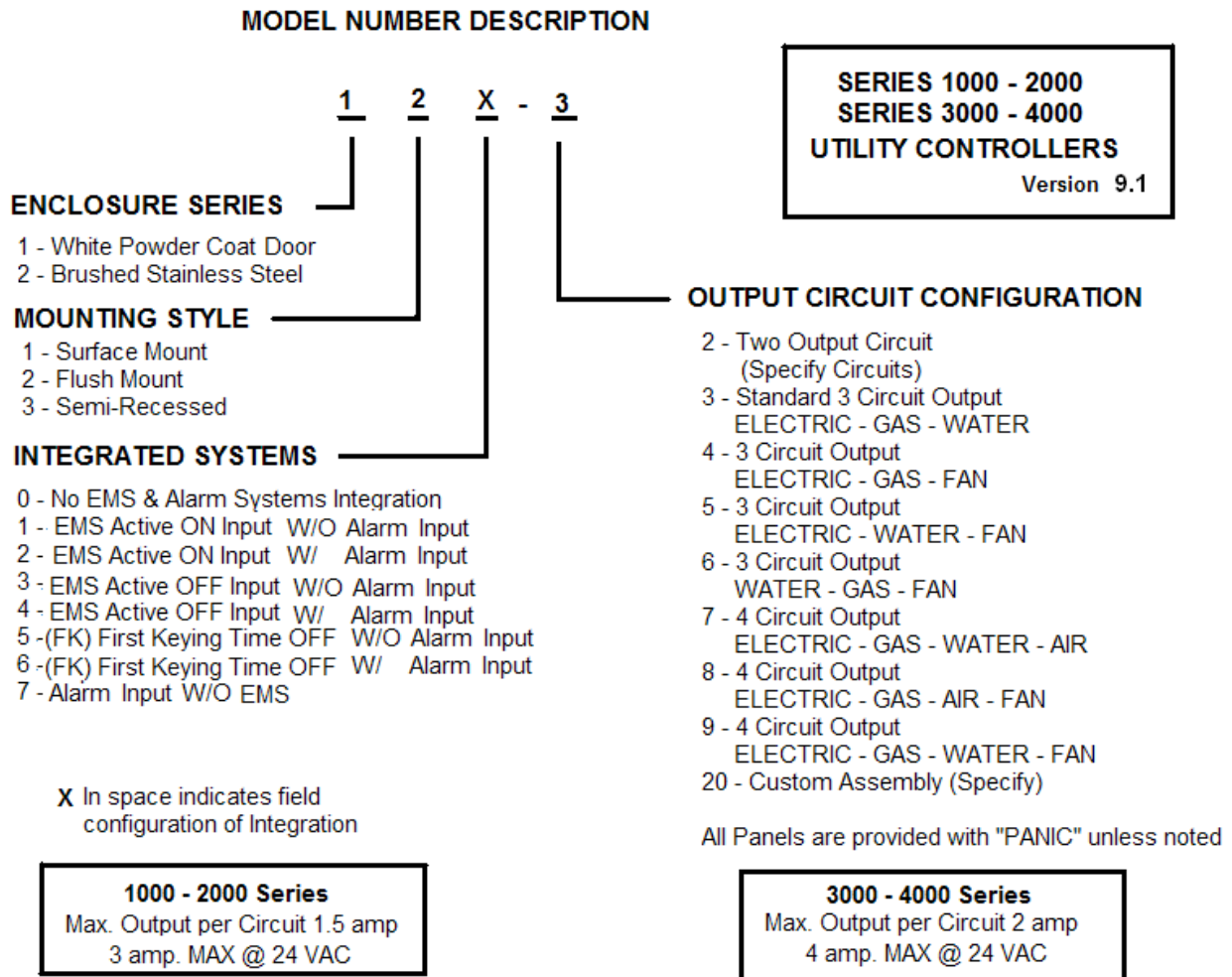

Utility Controller Illustration and Parts List

Figure 2 - Utility Controller

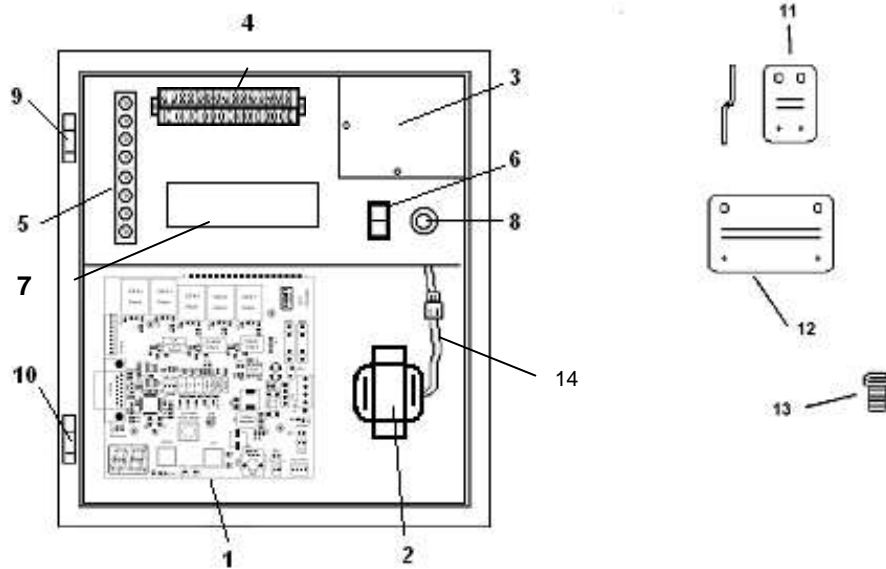

Utility Controller Primary Components

- 1 - Electronic Controller PCB
- 2 - 24 VAC Transformer
- 3 - Wiring Junction Cover
- 4 - Integrated Systems Terminal 1 See Fig. 13
- 5 - Controlled Service Terminal 2 See Fig. 4
- 6 - Control Switch S - 3
- 7 - Reset Panel
- 8 - Fuse Holder FH - 2
- 9 - Upper hinge pin assembly..... See Fig. 9
- 10 - Lower hinge pin assembly See Fig. 9
- 11 - Recess Mounting Flanges (4)
- 12 - Surface Mounting Flanges (2)
- 13 - 8-32 Self-Starting Screws
- 14 - Transformer Plug - Plug 1

Refer to wiring Schematics for all wiring components

Fuse Specifications

Fuse 1	5 X 20mm	2 Amp Slow Blow	PC Board Outputs W/ 3 amp Trans. W/ 12 vac circuit
		OR	
Fuse 1	5 X 20mm	3 Amp Slow Blow	PC Board Outputs W/ 3 amp Trans.
		OR	
Fuse 1	5 X 20mm	3 Amp Slow Blow	PC Board Outputs W/ 4 amp Trans W/ 12 vac circuit
		OR	
Fuse 1	5 X 20mm	4 Amp Slow Blow	PC Board Outputs W/ 4 amp Trans
Fuse 2	5 X 20mm	1 Amp Slow Blow	PC Board 12 vac circuit Output
Fuse 3	2 AG .177" X .57"	500 mA	PC Board Control Voltage
Control Panel	3AG .25" X 1.25"	5 Amp	120 Line Voltage

NOTE: Fuse 2 only used where unit operates 12 vdc latching solenoids for domestic water.
 Fuse 2 is omitted in all other cases. If Fuse 2 is present then Fuse 1 should be sized according to Fuse Specifications as stated above. Fuse 3 and Control Panel Fuse are fast acting fuses.

Door Panel Illustration and Parts List

Figure 3 - Door Panel

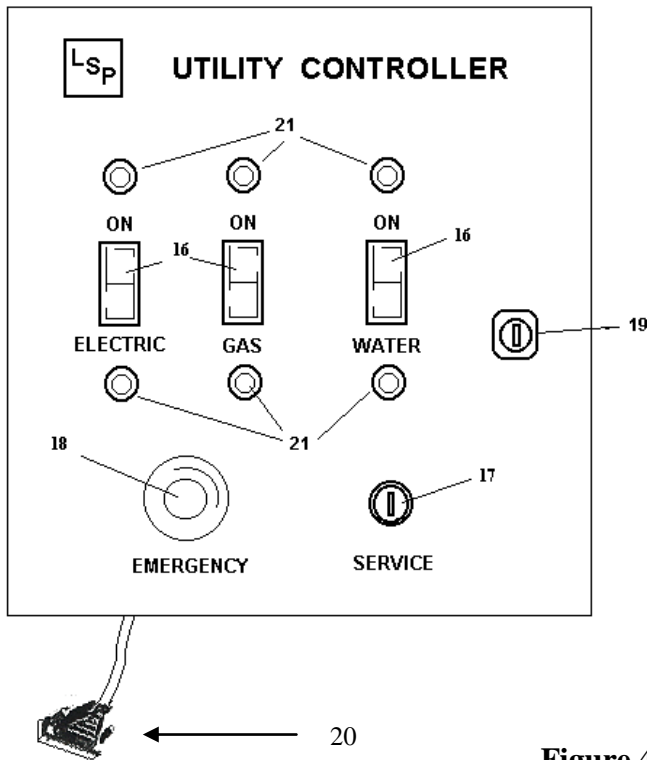

Door Panel Primary Components

- 16 - Service Switch (3) S - 4
- 17 - Keyed Switch S - 1
- 18 - Panic Button S - 5
- 19 - Door Panel Lock
- 20 - Door Panel Plug
- 21 - LEDs

Designator after part description references the component part number.

Note: Units having Auxiliary Circuit will have an additional Service Switch and Green LED placed adjacent to the Panic Button.

Reset fuses may be included in the Control Panel, and are intended to prevent circuit overload due to solenoid coil failure. Do not bypass or exceed output rating for the resets. Resets are integrally wired for specific use of the output circuit.

Figure 4 - 24 VAC Control Panel

Connect control wiring from integrated systems and monitoring devices to corresponding posts. See Figure 13 on page 20.

Connect 120 VAC Service in J-Box

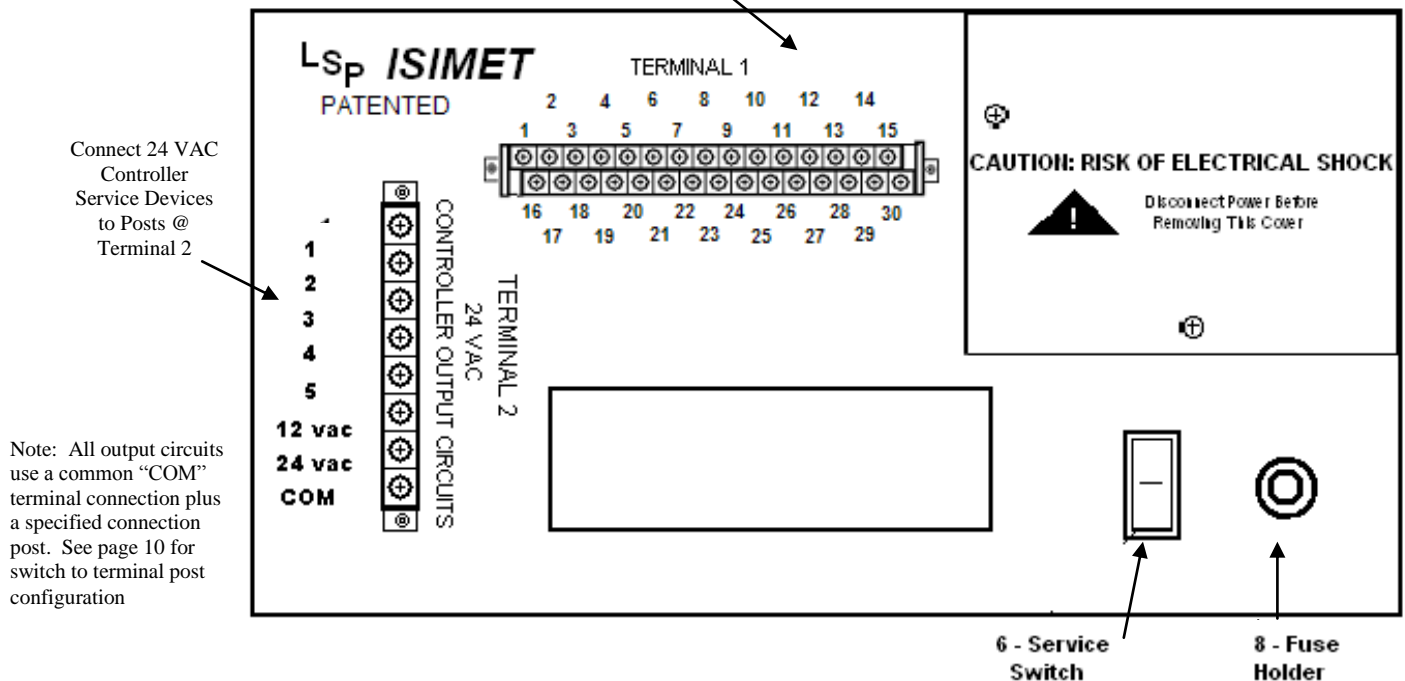

Note: All output circuits use a common "COM" terminal connection plus a specified connection post. See page 10 for switch to terminal post configuration

Installing the Utility Controller

CAUTION: Provided mounting hardware must be used.

The unit is provided with a protective cover over the enclosure. Care should be taken to insure that this cover remains in place until unit start-up.

There are two options for mounting the Utility Controller: Flush Mounted and Surface Mounted.

Flush Mounted (Figure 5)

Prior to installation:

- The Utility Controller easily mounts between two 11" spaced wall studs within a minimum 3 5/8" wall cavity for semi-recess installations or 4" for flush mounting. If stud spacing is greater than that required for the mounting of the controller, add studs to insure a secured mounting.
- The studs should be facing to facilitate securing the controller.
- Predetermine wall finish so that the face lip of the enclosure aligns flush with the finished wall surface.
- Actual physical dimensions are: 10" W x 12" H x 4.5" D.

To install:

1. Using the self-starting screws (13), mount the flanges at each side and at the top and bottom of the enclosure.
2. Attach the enclosure to the wall studs with field-provided sheet metal screws. (See Figure 5)
3. Level the Controller.

Notes:

- When the Door Panel is mounted onto the Controller, it should protrude beyond the wall surface about 1/4". Care should be taken at installation time to ensure that this occurs.
- A Flush Mounting Trim Flange is provided with each flush mounted unit. Separate installation instructions and hardware are included with this flange. Semi and Flush Trim adds 3 1/2 inches to both Height and Width Wall Surface dimensions.
- It is the responsibility of the installer to verify finish wall dimensions.

Surface Mounted (Figure 6)

Prior to installation:

- Wall finishes must be complete.
- The wall cavity must have sufficient backing or support to ensure a firm mounting of the controller to the wall surface.

To install:

1. Secure the surface mount flanges to the back of the enclosure with the self-starting screws (13).
2. Use the field-provided screws to attach the enclosure by the flanges to the wall surface.
3. Level the Controller.

Figure 5 - Flush Mounted

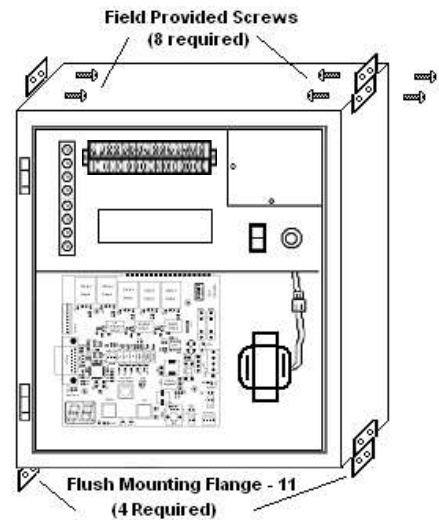

For best Flush Mounting results, recess face of enclosure's lip 1/2" behind wall finish

Clearance around Enclosure:

Care should be taken to allow 1/2" clearance from wall framing and sheet-rock or other wall surface material around the outer surface of the unit to permit the trim to be properly installed.

Semi-Recess Enclosure Placement

Note: For Semi-Recess Units, the face of the enclosure's lip should be positioned 1/4" beyond wall finish.

Figure 6 - Surface Mounted

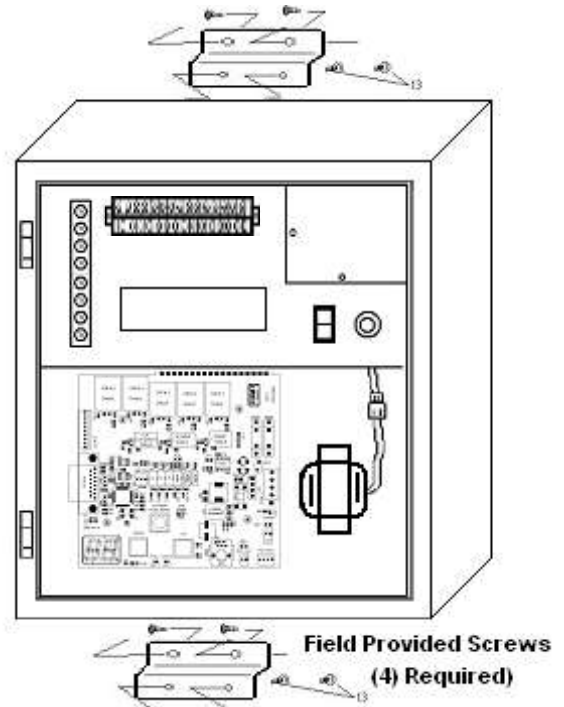

Installing the Electrical Conduit

Several knock-out holes for connecting the conduits are located at the top and at each side of the Utility Controller.

- Connect rigid conduit for the required 120 VAC electrical service at the top right or side opening as indicated in Figure 7.
- Connect conduit for integrated services such as “EMS” (Energy Management System) and building alarm at the top of the enclosure.
- Connect conduit for the controlled utility services to the upper left top or left side of the enclosure.

Important!

- All local codes must be followed when installing this unit and connecting the conduit and wiring to the service panel.
- Do not install wiring or cable for integrated systems, LA Companion Units, remote panic assemblies or other interface wiring within conduit for either 24-vac control or 120-vac line voltage. Each wiring system should be housed in independent conduit and not bundled with wiring from other systems or control units.
- Failure to comply with these wiring specifics may create transient voltage at the pc board and cause system malfunction and/or failure.

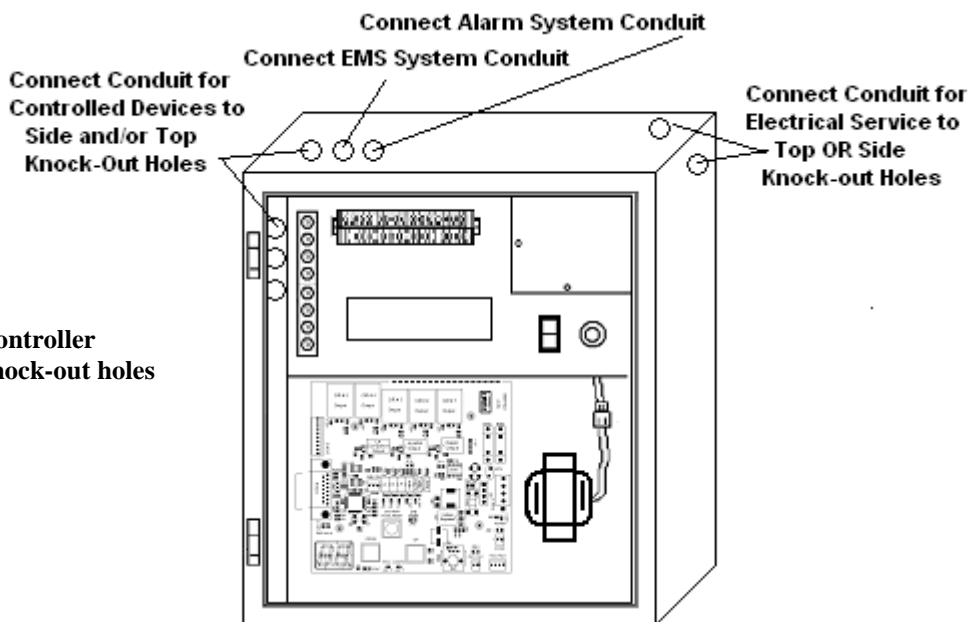

Figure 7 – Controller Knock-out holes

Wiring the Utility Controller

Important!

Verify that the electrical supply is disconnected prior to connecting wiring to the Utility Controller.

To wire the Utility Controller:

1. Remove the junction box cover (Item 3, FIG. 2) from the panel surface.
2. Make final connections to the 120 VAC electrical service to wiring within the junction box. Verify that line wiring (Black), neutral (White), and ground wire (Green) are correctly connected. Minimum recommended wire size is 14 AWG.
3. Replace the junction box cover before activating or testing the unit.

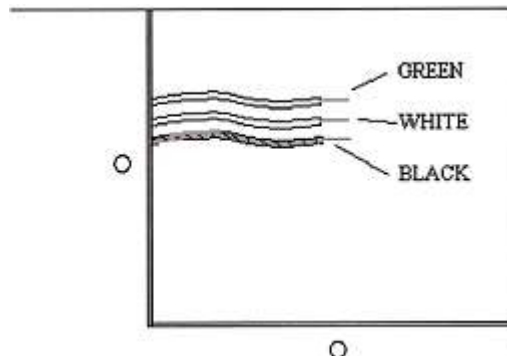

Figure 8

NOTE: Only qualified craftsmen licensed within the governing jurisdiction to perform the work associated with this installation should install and/or service this equipment.

Connecting Controlled Utility Services

The Utility Controller is not provided with electrical solenoids, contactors, or relays. *ISIMET* provides a full line of Companion Enclosures and fittings. It is recommended that these items be included in the system design, but when the installer elects to provide these fittings from other sources, compliance with product specifications must be confirmed prior to installation. The unit is equipped for 24 VAC output for control of the devices. Connect wiring for these devices to Terminal 2 at designated posts. All output circuits use a Common and a designated output terminal post.

NOTE: Place relays and solenoids in areas that are easily accessible for future maintenance.

Door Panel Switch to Terminal 2 Configuration: (typical)			See
Typical Usage	Service Switch	Standard Application	Figure 4
Electric Service	Switch 1	Circuit 1	Post 1
Natural Gas	Switch 2	Circuit 2	Post 2
Domestic Water	Switch 3	Circuit 3	Post 3
Purge Fan	Switch 4	Circuit 4	Post 4
Remote		Circuit 5	Post 5
12 VAC		Unswitched Leg	Post 6
24 VAC		Unswitched Leg	Post 7
24/12VAC		Common	COM

Note: Use of primary outputs may be changed to accommodate specific project requirements. Where only two primary outputs and purge fan are included in the assembly then the purge fan circuit replaces the third standard output. The logic code is modified to accommodate this change and pcb configurations are slightly different but noted in the configuration section of this manual. Refer to page 21 and 22.

Remote Circuits

If the Unit is equipped with remote circuit outputs, make 24 VAC output control wiring connections at Terminal 2.

ISIMET Applications use low pressure differential / low wattage normally closed solenoids for piping systems. If solenoids other than those provided by *ISIMET* are used in the application, it is **STRONGLY** recommended that only this type of solenoid be provided. Additionally, it is recommended that if compliance with product specifications is not factory certified then operating power for the solenoid should be provided from sources other than the Utility Controller.

ISIMET Applications use mechanically held Square D Multi-pole Lighting Contactors to control the 120 VAC circuits to the convenience outlets. Square D - Definite Purpose Contactors are used when a controlled device load demand exceeds normal operating amperes. All E-Series Companion Enclosures are equipped with an interface relay to enable the Utility Controller's output circuit to operate the contactors. If relays or contactors other than those provided by *ISIMET* are used in the application, it is **STRONGLY** recommended that only this type of contactor be provided. Additionally, an interface relay will need to be provided to insure compliance with application installation requirements.

Connecting "EMS" (energy management system)

Note: Refer to PC Board Configuration details on Figure 12, Page 19 for locations and placements of "EMS" config. jumpers.

"EMS" Input

- If the unit is factory configured to operate with an "Active ON EMS" signal, a jumper @ CON 8 is placed across the right two posts. Once the Start-up Procedure has been performed and an "EMS" Input signal is present, remove the jumper @ CON 8.
- If the unit is factory configured to operate without "EMS" or as an "Active OFF" signal, no jumper @ CON 8 is present.
- If 24-vac "EMS" input is utilized, then referring to the configuration details, remove the jumper if in place @ JP 5.
- If 5-vdc "EMS" input is utilized, then place a jumper @ JP 5.
- If the "EMS" input is through a dry-contact relay provided by others place two jumpers across JP 10.
- If the Unit is configured to operate with the MASTER Time OUT function, After the First Keying of the Unit the Timing Function will automatically turn OFF all connected Operators once the determined Timing sequence has expired.
- **CAUTION:** Verify "EMS" input control voltage available and confirm that configuration jumpers on the PCB has been properly configured prior to placing the unit in operation. See **Start Up Test Preliminary Information** on page 14 for description of the "EMS" and "alarm" configurations, and configuration diagrams on page 19.

PC Board LED Indicator Chart:

Refer to configuration chart on page 19 for locations.

LED Description	Function	Comments regarding illumination
Power – LED 9	Power Supply Function	Power supply failure if not illuminated
PANIC RESET Button	Indicates System is in “Panic”	Unit will not function until RESET
EMS – LED 16	Indicates “EMS” operation	If Configured for EMS; Unit will not function unless illuminated
Alarm Input – LED 10	Indicates Input “alarm”	Unit will not function or reset until “alarm” signal is withdrawn
Panic Input – LED 14	Indicates Input “Panic”	Unit will not function or reset until isolated signal is withdrawn
LED J1	Monitored Input	Not used in this Unit Series
LED J2	Fuel Gas Sensor Input	Unit will not function or reset until isolated signal is withdrawn
LED J3	Secondary Panic Input	Unit will not function or reset until this secondary isolated signal is withdrawn
RTCC LED	Clock LED	Indicates that Micro-Controller on pcb is Functioning.

Connecting Alarm and Monitoring Wiring

Note: Refer to PC Board Configuration details on Pages 19 & 20 for locations and placements of all configuration jumpers.

Alarm Input / Output

- The unit will operate without an “alarm” input signal.
- Providing an input signal from the alarm system at Terminal 1 (FIG. 13) will disable the Controller upon a fire alarm.
- 24-vac/dc or Dry-Contact active OFF “alarm” input will disable the unit. Placing a Jumper @ JP 5 changes input to accept a 5 vdc input for Alarm. The Alarm Input terminal can be utilized when a dry-contact type Alarm Module is inserted into the Controller.
- If an Exhaust Fan Circuit is included and it is desired to have this fan operate with ALARM then make connections from the Alarm System to either the ‘Remote Panic’ or ‘Auxiliary Panic’ Input Posts at Terminal 1.
- Upon receipt of an “alarm” signal, a 24 vac output is provided and dry-contact is closed, these output signals may be used for “User Defined” operation of another monitoring device.
- If the Alarm input is through a dry-contact relay provided by others place two jumpers across JP 11.
- Optional 24-vac output and dry contact points are available at Terminal 1; “Alarm Monitoring” (FIG. 4) for monitoring by the building alarm system. Refer to Configuration chart on pages 19-20.

Auxiliary Panic Input

- Optional Panic Input posts are available. One or more *ISIMET* Remote Panic Buttons can be connected in parallel. This terminal point transmits a 24-vac signal that is returned to the pcb when the remote panic is pressed.

Isolated Panic Input

- An isolated 24-vac/dc input signals, such as the *ISIMET* Emergency Shower Monitoring Station or a “user defined” monitoring device. Upon receipt of an input signal, the unit will be placed into “Panic”.

Panic Output

- Optional 24-vac output or reconfigured dry contact points are available at Terminal 1; “Panic Output” for monitoring by the building alarm system. Refer to Configuration chart on pages 19 & 20.

Connecting Optional Monitoring, ADD-ON Module & Communication Inputs:

ISIMET provides a full line of monitoring light arrays and panels for integration with the safety control system.

- Monitoring Lights are connected in parallel to the output circuit on Terminal 2 at each output source.
- The Monitoring Beacon or Remote Monitoring Station is connected at the “Panic Output” posts on Terminal 1.
- Remote panic assemblies are connected on Terminal 1.

If the Optional Interface Input are through a dry-contact relay provided by others place two jumpers across the Jumper post as indicated per “Optional Input / Output Signal Configurations” on page 20.

LS Style – RF Control Module can be added at any time to Version 9.1 Controllers by removing the three (3) jumpers on CON 5 and inserting the RF Module connector. Complete installation and configuration instructions are provided with that unit.

The LA-Series Controller is available for integration with the system to permit selective operation of a secondary workstation, such as an instructor’s desk or Prep area. Optional 24-vac output and dry contact points are available at Terminal 1. Additionally, Inputs are available to connect the Panic Output from the Companioned LA Unit to the Controller. These LA Inputs will place the Unit in “Panic” without re-transmitting a Panic signal to other Companioned LA Units. These inputs may optionally be used as additional Auxiliary or Isolated Panic Inputs were no LA Units are companioned to the Controller.

Wiring configurations for each optional component is provided with that device. **DO NOT** install wiring from any Add-On component within conduit contacting either 24-vac control or 120-vac line wiring.

Refer to configuration diagrams on pages 19 & 20 and Typical wiring schematics on page 23 for details on these connections.

Installing the Door Panel

Installing the Door Panel (Figure 9)

To install the Door Panel on the Enclosure:

1. Position the door at 90° – 100° of enclosure. (STEP 1)
2. Slide top hinge pin onto fixed hinge post at top of door. (STEP 2)
3. Slide lower hinge pin toward lower spring hinge mechanism with hinge pin lever in retract position. (STEP 3)
4. With lower hinge pin in position, turn hinge pin lever outward and down, then turn inward to the extend lock position. (STEP 4)

90°

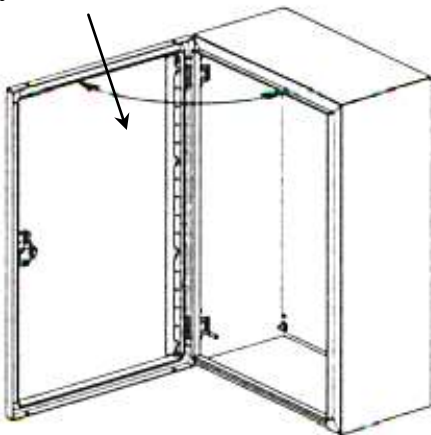

STEP 1

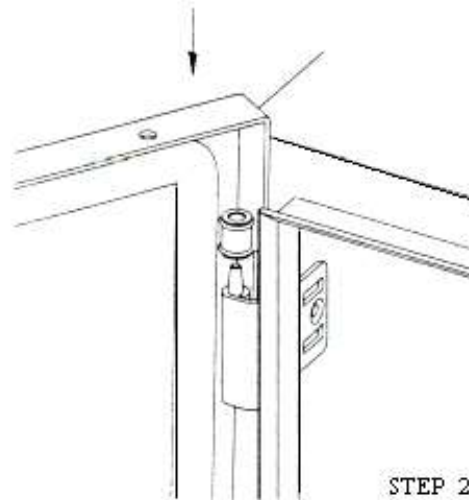

STEP 2

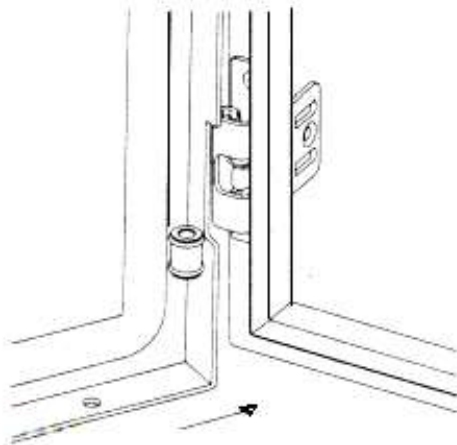

STEP 3

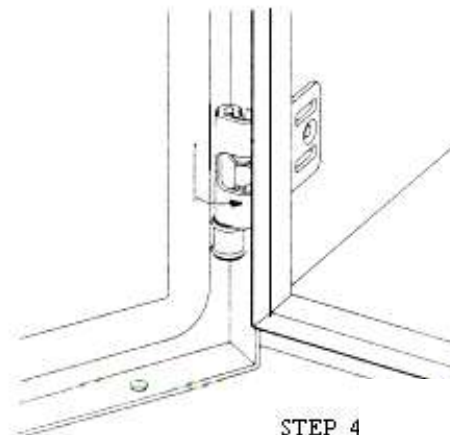

STEP 4

Installing Flush Door Trim

Figure 10 - Flush Door Trim

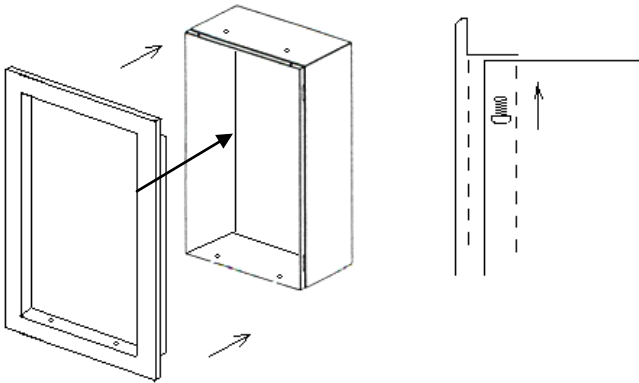

Prior to installing Door Trim, ensure that wall finishes are complete and that the door panel has been installed.

To install the Flush Door Trim:

1. With the door in the open position, slide flush door trim over enclosure. See Figure 10.
2. Align holes on enclosure with upper and lower holes in door trim.
3. Insert four (4) 12-24 (provided) screws through enclosure panel and tighten into door trim.

Notes: Holes in enclosure are slotted to allow installer to adjust trim to wall finish.
Flush Trim adds 3 1/2" to both Height and Width Wall Surface dimensions.

Figure 11 - Printed Circuit Board

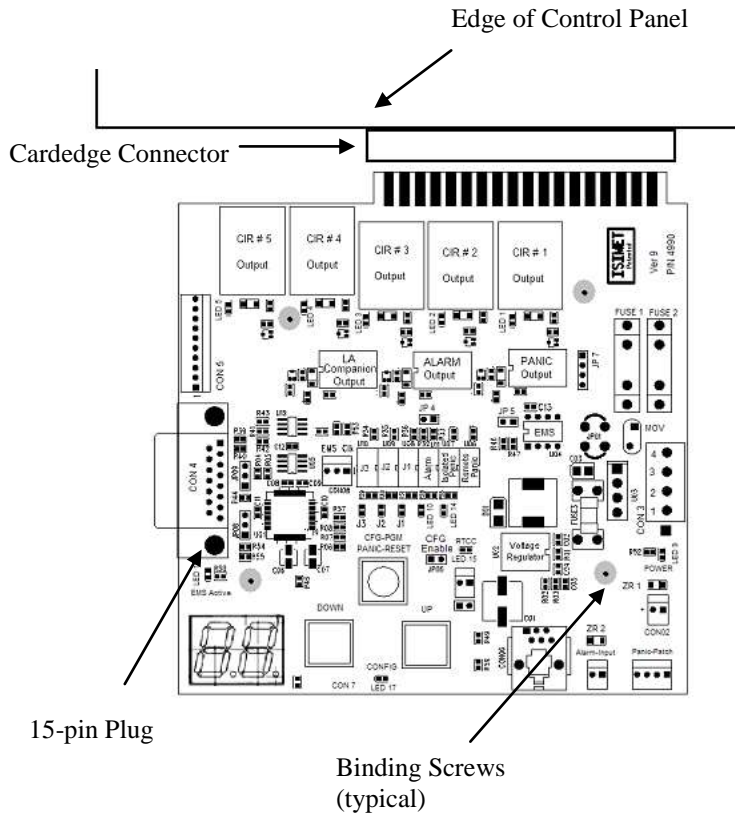

Connecting the Door Panel Plug

1. Remove the protective covering from the plug and PCB and insert the plug into the Door Panel terminal located at the base of the PC Board.
2. Secure plug to the terminal with the provided 4/40 machine screws. See Figure 11.

Note: This 15-pin plug is polarized. Exercise caution when inserting it into the terminal.

The Version 9.1 PCB is configured so that this connector is positioned vertically along the inner side of the enclosure.

Removing the pcb "Printed Circuit Board"

- Disconnect wire leads from the transformer @ CON 3.
- Disconnect any other leads connected to the pcb.
- Remove the binding screws that hold the pcb.
- Slide the pcb downward from the Cardedge Connector.
- When reinstalling, repeat above steps in reverse.

Start-Up Checklist: A separate Start-Up Test Sheet is provided with the installation CD. The tests described herein and in those procedures should be followed prior to placing the unit into operation. If you do not have on hand this CD and/or Start-up sheet, you may retrieve a copy from your local factory representative.

NOTE: Examine the pcb to verify that the Voltage Regulator is in place. If not, contact your Manufacturer's Representative. They will provide this device and assist with Start Up Procedure. Refer to Figure 12 on Page 19 for the location of the Regulator. If this Regulator is in place, then you continue the Start Up Procedure.

Caution!

- **Verify that ALL installation procedures and Line Voltage, EMS, Alarm, Remote Relays, and/or Solenoids conform to Equipment Specifications.**
- Examine electrical wiring at junction box to verify that ALL wiring is correctly connected.
- Examine **Terminal 1** and **Terminal 2** to assure that wiring has been properly connected. Test Output circuits at **Terminal 2** to verify that field wiring or connected devices are wired correctly. A direct short or input voltage at the output circuit will cause damage to the PCB and Controller.
- Verify that the Door Panel plug is firmly secured to its terminal.
- Examine Door Panel factory wiring to ensure that it was not damaged or loosened during shipping or installation.
- If unit is integrated with "EMS", verify that wiring is installed at correct terminal posts. Verify that input voltage conforms to unit specifications.
- If unit is integrated with an alarm system, verify that wiring connections, voltage requirements, JP 4 configuration, voltage requirements, and alarm system conform to unit specifications.
- Remove all dust and construction debris prior to proceeding.

Start Up Test Preliminary Information

Caution!

- Do not proceed with equipment start-up until the Start-Up Checklist has been completed.
- Before commencing these Start-Up tests, turn the control switch to the OFF position.
- If the unit is integrated with a monitoring system, disconnect wiring from posts "Panic Output" at Terminal 1.

This unit was factory tested, but the manufacturer recommends that the installer perform these tests to ensure that the unit did not sustain damage during shipment or installation.

- Perform Start-Up Tests with the Door Panel open.
- If the unit is factory configured to accept an "Active ON - EMS" timing control input signal, a jumper is present @ CON 8. (jumper is at the right two posts) so that the unit can operate without an "EMS" signal with the control switch ON, "EMS Active" LED on the PCB should illuminate. If yes, the remainder of the "EMS" test can be skipped. If not, check circuitry for proper "EMS" input voltage at Terminal 1. If "EMS" is set to "Active ON" and if "EMS" is active after this test, remove the jumper.
- If the "EMS" signal is to be provided as 5 VDC, place a jumper at JP 5. Caution, DO NOT leave this jumper in place if the unit will be time controlled by a 24 VAC/DC input signal. Additional jumpers are provided in the O&M paperwork packet.
- With the control switch ON, "POWER" LED 9 on the PCB should illuminate. If not, check circuitry for 24-vac power at CON 3, pins 2 and 3. Next, check the PCB fuse 3 (2 AG-500 mA). If the fuse is functional, then 5 vdc should be read across the 2 pins on CON 2. Care should be taken to not short across these two pins. If not, re-verify that fuse 3 is operational.
- LED 15 "RTCC" should pulse at about once every two seconds.
- If after performing these tests and verifying operation, if the Unit fails to function contact an *ISIMET* factory representative.

Start-Up Tests

A. Testing the Control Wiring and Service Switches

1. Turn the control switch to the **ON** position (Item 6, FIG. 2). It should be illuminated. If it is not, check current at wiring within the junction box. Voltage should read 120 VAC. If it does not, consult an electrician before continuing this testing.
2. Turn the first service switch to the **ON** position. The other switches should be **OFF**. (Items 16, FIG. 3)
3. Insert the key at the keyed service switch and turn clockwise and release. The green indicating light above the service switch should be illuminated. This indicates that the service is active. Also the corresponding LED on the PCB will illuminate. Using testing probes, verify that the corresponding terminal posts at Terminal 2 (FIG. 4) are energized. Refer to the wiring diagram and "Door Panel Switch to Terminal 2 Configuration" on the back of the Door Panel to verify the correct posts. Turn the switch **OFF**. Note: The PC Board is equipped with a 5 mm, output fuse (fuse 1). If 24-vac is not present between the top two posts @ CON 3, check for a damaged fuse.
4. Repeat steps 3 and 4 for the remainder of the service switches, as well as any Auxiliary Circuits, except that Auxiliary Circuits have green panel LED indicators only.
5. Turn all service switches **ON**. Again, engage the keyed service switch. All services should be **ON**. All green indicating lights should be illuminated. Verify **ALL** power loads with test probe.
6. Turn service switches **OFF**. The RED LED below each service switch should be illuminated.

B. Testing the Panic and Alarm Systems

Note: (Alarm input will deactivate the unit when configured per unit specifications)

The PC Board is equipped with a 5 mm- 5 amp Monitoring output fuse (fuse 2). If 24-vac is not present between the top post and Post 2 @ CON 3, check for a damaged fuse.

1. If the unit is integrated with a monitoring system:
 - a. Verify that the monitoring system is **OFF** or that the unit has not been fully integrated with the monitoring system.
 - b. Disconnect the wiring from Terminal 1, "Panic Output" posts. (FIG. 13)
 - c. Press and release the red panic button. **ALL** door panel indicating lights should be illuminated. **If not integrated with a monitoring system, skip the remainder of this test.**
 - d. Use test probes to check current at 'Panic Output' posts (FIG. 13). Dependent on configuration, either continuity or 24 VAC should be present across posts 11 & 12 while in "Panic".
2. Press the reset switch on the PC board. The Door Panel indicators should **ALL** lose illumination.
3. Re-check continuity or voltage. None should be evident.

Reset Configuration: The unit can be field configured to either require reset after panic at the PC Board Reset or by re-keying the door key switch. Refer to "Configuration of Programming".

Remote Panic Assembly: The unit will accept integration of an *ISIMET* Remote Panic Assembly. If one is provided, wiring connections can be made at Terminal 1. Directions are provided with that remote assembly.

C. Testing the "EMS" and alarm Input signals

The unit has been factory tested to assure that both "EMS" and "alarm" Inputs perform correctly. Field verify that jumpers on the PC Board are correctly configured to accept correctly provided input signals. Verify that the "EMS ACTIVE" LED is illuminated. Confirm that if 24 VAC is available at "EMS Input" posts on terminal 1. (FIG. 13) and verify that no jumper is located on PCB - JP 5. If in place, damage to the components on the PCB could occur. If the unit is configured for dry-contact input then verify that jumper arrangement complies with the Signal Input Configurations Chart on page 20.

D. Testing the Building's Utility Systems

1. Turn **ALL** control switches **ON** and engage the keyed service switch.
2. Field-test **ALL** utility and appliance outlets to confirm that services have become active.
3. Turn the switch for each utility to **OFF**. Verify that the specific utility outlets are not active or "**ON**".

E. Test Completion

The unit should now be fully operable. If it is not, contact an *ISIMET* Service Representative.

1. Turn the Control Switch **OFF**.
2. Reconnect **ALL** integrated services.
3. Replace **ALL** panels and covers.
4. Turn the Control Switch **ON**.
5. Close and lock the Door Panel.

Equipment Operation

Note: The Utility Controller should be operated by an instructor possessing only the service switch key. Once the unit has been thoroughly tested, the installer should provide keys on separate rings to the property owners, administrators or their representatives. The Utility Controller is intended to function as a control system for the utility services and devices located within the room. The keyed switch provides for security against unauthorized use of the services.

CAUTION: Having outlets such as Gas Turrets Open when Services are activated can result in injury or death. Verify that these outlets are closed prior to activating the unit.

To Activate One or More of the Services Controlled by the Unit:

1. Turn **ON** the corresponding switch for the service you wish to activate.
2. Insert the key in the switch labeled “SERVICE”, turn to the right and release.
The service has been activated and the Green LED above the switch will illuminate.
3. Remove the key and place it in a secured location.

To Turn a Service OFF:

Turn the appropriate switch to **OFF**. The Red LED will illuminate. It is not necessary to reinsert the key.

Notes:

- You must reinsert the key to reactivate services that were deactivated by turning the switch to **OFF**.
- A service left **ON** remains **ON** until its switch is turned **OFF** unless the Panic button is depressed or line voltage is removed from the controller.

To Activate the “Fan” Circuit (Optional):

Fan circuits require only first keying to activate. This means that once the Fan or any other circuit has once been turned **ON**, the Fan switch will turn **ON** and **OFF** that device without the typically required re-keying. Also, upon Panic, the Fan will automatically turn **ON**, and upon an “alarm” Input will automatically turn **OFF**. If the Fan circuit is set with Fan Timing Feature then whether the Fan is operated by switch or Panic, the Fan will turn **OFF** at end of timing cycle.

Circuit Timing OFF Feature: Table # 1: Programmable Inputs and Table # 2: Circuit Function Criteria

If Position 7 “Circuit Timing” is set to other than “0” and criteria at least one circuit is set to respond to circuit timing then those circuits will turn **OFF** after the circuit timing cycle expires. The timing cycle begins with the activation of the first circuit and expires for all designated “cycled” circuits simultaneously at the completion of the current cycle. Turning **OFF** all switches will reset this cycle as will expiration of the “EMS ON” cycle. However, Panic or any other interrupt signal will not reset this timing.

Gas Detector and Secondary Sensor Interface: If a Fuel Gas Detector detects Raw Fuel Gas and transmits a control signal to the Controller, the RED LED on the Door Panel for each Circuit that is affected by the Detector will flash. If the Secondary Sensor transmits a control signal, the RED & GREEN LEDs for the Gas Circuit will both flash.

In Case of an Emergency:

Press the red panic button on the door panel. This will disable the panel and **ALL** services. All LEDs on the door panel will be illuminated. If the unit is integrated with building monitoring systems, a Panic signal will be sent to that system. Once the panic button is pressed, either the door panel must be opened in order to press the reset switch located within the panel; or if configured for re-keying, the door panel keyed switch will reset from panic. Also, the door panel LEDs will remain lit until reset is accomplished.

If You Cannot Activate the Services:

Check for one of these signals: There may not be an electronic signal from the building “EMS” (Energy Management System); there may be an “Alarm” signal from the building alarm system; there may be an Isolated Panic Signal from an integrated system; or the system may be in the “panic” state. When the unit is integrated with either the “EMS” and/or the Alarm system, a second level of security is in place because, without an electronic activation signal from the “EMS” or lack of signal from the Alarm, the unit **WILL NOT** function. Unauthorized access to the services is prevented during times when the building or classroom is normally unoccupied. However, if room air conditioning or heat is operational, the unit should function.

At the End of the Day:

ISIMET recommends that each service switch on the door panel be turned **OFF** prior to exiting the room. Also, the service key should be removed and placed in a secured location. The unit, when integrated with an “EMS”, provides a secondary safety feature that automatically turns **OFF** any services left **ON** at the end of the “EMS” cycle. If, when re-entering the room, you notice that a Red LED is illuminated, you will be reminded that service was previously left active after exiting the room. If the Unit is configured to operate with the First Key Time OUT function (**Configuration 3, Position 2 on Table # 1**), after the First Keying of the Unit the Timing Function will automatically turn **OFF** all connected Operators once the determined timing sequence has expired.

Troubleshooting (A troubleshooting guide slide is available on the ISIMET Product CD)

If the Utility Controller fails to energize, follow these procedures: Refer to LED Config. chart on page 11.

- Verify that the Controller has correct line voltage connected. With the control switch (6) in the **ON** position, the switch should be illuminated. If it is not, check the wiring connections. Remove the wiring junction-box cover and examine wiring connections.
- Examine the removable fuse on the Service Panel. If it is damaged, replace it. Verify fuse rating with **Equipment Specifications**. Models 1000 and 2000 use 5 mm fuse @ PC Board fuse 1 and fuse 2, and 500 mA @ fuse 3, and 5 amp fuse at in the Control Panel fuse holder.
- Power Supply @ pcb. Power LED 9 will illuminate when 5-vdc is present on pcb.
- RTCC LED 15 will pulse with Power ON.
- Verify that the Door Panel plug is securely connected to the door terminal.
- Check the wiring terminals on the door panel to verify that none has become damaged or disconnected during installation. Reconnect, if necessary.
- If “EMS” is integrated, verify that the Controller is receiving the correct volt signal at Terminal 1, “EMS Input” posts Refer to **Equipment Specifications** and the “EMS” connection section of this manual for these requirements and additional tests to conduct. In most cases, the failure of the system is the result of a lack of proper signaling from an “EMS”. The “EMS” LED on the PCB should be illuminated.
- If any of J3, J2, J1, “Isolated Panic” or “Alarm” LEDs are illuminated, the system will not function. Verify that no input signal has disabled the unit. If the “panic” LED is **ON**, press the panic reset switch on the PCB. Test for static input voltage at the wiring leads connected to the AUX. PANIC INPUT and/or other INPUT terminals. Static voltage across this wiring will cause damage to the PCB.
- With Door Panel switches in the **ON** position and the keyed switch activated, check the Door Panel Green LEDs.

If Door Panel Green LEDs are illuminated:

1. Check current at service utility Terminal 2. Refer to **Door Panel Switch to Terminal 2 Configuration** chart on page 10. You should read the correct voltage at these terminal posts. If not, check Fuse 1 on the PCB.
2. If you do not read the correct voltage, contact an **ISIMET** Service Representative.
3. If you read the correct voltage, test the remote relay and/or solenoids to verify that they are operational.

If Door Panel Green LEDs are not illuminated:

1. Examine the PCB. One PCB mounted LED (LED 1, 2, 3, 4, or 5) should be illuminated. If it is not, check the removable fuse 3. It is a 500 mA fuse.
2. If the fuse is damaged, replace it.
3. If the LED still does not illuminate, contact an **ISIMET** Service Representative.

In many cases, failure of the system is the result of improper connection of a remote service or device such as a remote relay, solenoid, “EMS”, or building alarm. Refer to **Equipment Specifications** to confirm that correct connections to these services and devices have been made.

Notes:

- It is not uncommon for the Utility Controller to enter the “Panic State” when first activated when the control switch is turned **ON** and an input signal is received. Pressing the RESET Switch or Re-Keying the door panel key will immediately return the controller to the correct “Waiting State”.
- Damage to the Electronic Controller and other components can occur from improperly connecting the services, overloading the output circuits, or failing to follow all start-up tests and checklists.
- In **ALL** cases, if the system fails or you have questions about the equipment, contact an **ISIMET** Service Representative.
- If the results of all test procedures is positive but utilities will not activate, **ISIMET** recommends that you examine and test the various utility services controlled by the unit to verify that they are operational and active.

CAUTION:

The output circuits of the Controller provides 24 VAC control signals to solenoids and relays to activate and engage the various utilities. **ISIMET** provides a full line of Companion Enclosures and fittings. It is recommended that these items be included in the system design, but when the installer elects to provide these fittings from other sources, compliance with Product specifications must be confirmed prior to installation.

If utilities or controlled devices remain operational after the service switch is disengaged, check for the following before placing the unit into full operation:

- A defect in the remote relay or solenoid
- Tampering
- The remote relay unit has a control switch with a manual operation position and the switch is in the manual position. If utilities or devices continue to be active or if you have a question about the operation of the unit, contact an **ISIMET** Service Representative immediately.

Equipment Maintenance

(Recommended maintenance guide slide is available on the ISIMET Maintenance CD)

- ❑ The Utility Controller should have semi-annual inspections.
- ❑ *ISIMET* recommends opening the service panel and turning OFF the control switch prior to long periods of inactivity in the building.
- ❑ Prior to anticipated activity within the building, *ISIMET* recommends that you conduct a brief test of the control system by performing Start-Up Test Procedure A and Step 1 of Procedure B on page 15 of this manual.
- ❑ If examination of the unit indicates tampering, *ISIMET* recommends that you first review the Start-Up Checklist, then conduct **ALL** Start-Up tests.
- ❑ The Door Panel lock is not keyed the same as the keyed service switch. *ISIMET* recommends that the door panel key be kept separate from the service switch key and in a secured location. The door panel key should be available only to those needing access to the interior of the unit for the purposes of maintenance or service. *ISIMET* recommends that the door panel remain locked unless service is performed.

If you have any questions regarding the operation and maintenance of the Utility Controller, please contact an *ISIMET* Service Representative.

The enclosure has a NEMA 1 rating. It is not intended for use in wet areas. Exercise caution to prevent exposure of the interior compartment of the enclosure to moisture. If moisture is present within the enclosure, *ISIMET* recommends that the control switch be turned **OFF**, power be disconnected from the unit until the source of the moisture is determined, and all moisture is removed from the compartment.

The electronic controller (PCB) is sensitive to moisture, dust, debris and other air-borne particles. Do not expose the interior compartment of the enclosure. During the semi-annual inspection, if dust or other material is present, *ISIMET* recommends that you remove all foreign matter before operating the unit.

If the Unit fails to operate, we recommend that you check the power supply to the unit. With the control switch in the ON position, it should be illuminated if power is on to the unit. If not, check the service breaker.

If the control switch is illuminated, check the fuse on the control panel at fuse holder 8. If the fuse is not damaged and the “EMS” LED on the circuit board is not illuminated, then you should verify that the unit is receiving the proper “EMS” and “alarm” signals. We recommend that you perform the Start-Up Checklist and Start-Up Tests.

If the unit still does not function, we recommend that you check the three fuses on the circuit board. The input fuse is 2AG 500 mA. The unit will not function properly with these fuses damaged. If damaged, replace the fuse.

If the unit still fails to operate, we recommend that you contact your local Service Representative.

Removing the Door Panel

Before removing the Door Panel, turn power OFF at the control switch, then disconnect the plug from the terminal within the enclosure (Figure 11).

Follow steps 1 – 4 in reverse as shown in Figure 9.

Instructions for Re-coating the Enclosure

If the finish surface of the enclosure or door panel becomes scratched, follow this procedure to repair the surface.

- Most standard, good quality paints can be used to re-coat the polyester powder finish.
- For best results, correct surface preparation before re-coating is essential. Follow instructions provided by your paint manufacturer.
- Wipe surfaces to be painted with either xylene or lacquer thinner solvent.
- Allow surface to flash dry prior to painting.
- Follow paint manufacturer’s instructions for applying paint.
- Allow paint to cure adequately. Consult the paint manufacturer for proper cure time and hardness.

ISIMET Utility Controller PCB Version 9.1 - Jumper Configuration

Optional Input / Output Signal Configurations

Figure 12

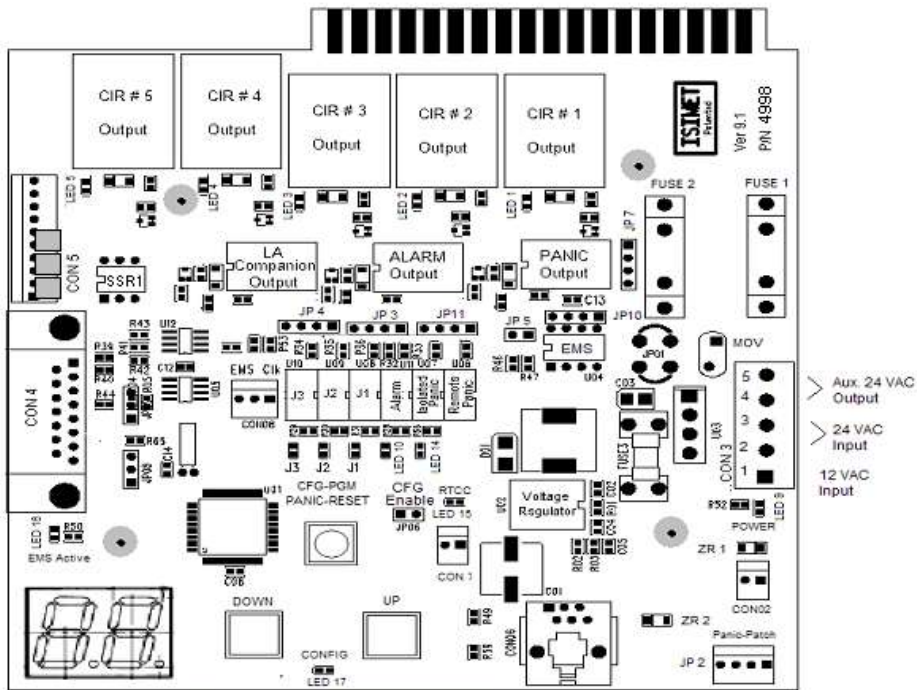
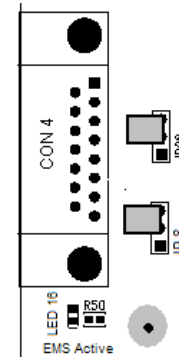

Figure 12-A



JP 9 & JP 8
Configured for Auxiliary
Switch 4.

Figure 12-B



JP 7 Configured for
24-vac Output
@ Terminal 1,
Pins 11-12

Jumper Post – Connection Configuration

CON 2	Aux. 5 VDC Output	(Use only by Written Instruction)
Caution: DO NOT Place a Jumper Across any Pins on this Connector.		
JP 8	Panel Switch # 4 Option	Center – Lower Jumper: NO Switch 4 Available Upper – Center Jumper: Switch 4 Active
JP 9	Switch # 4 LED Option	Center – Lower Jumper: NO Switch 4 LED Upper – Center Jumper: Switch 4 LED
JP 5	EMS Input	Place Jumper Only When Input is 5 VDC; Otherwise Remove Jumper
CON 5	LS series RF Input (optional) Standard config.	Ten pin connector permits RF Input Module to be integrated into the unit. Jumpers across pins 5 & 6; 7 & 8; 9 & 10
CON 8	EMS Clk	Right – Center Jumper: Factory installed to allow temporary operation during Testing and Start-up. Remove Jumper and see Programming Configuration Notes once Unit Start-up is Certified.
JP 2	Panic-Patch Standard config.	Used in Cases when Transient Voltage Causes Interference from a Connected Remote Panic. Use only with Factory Provided <u>PATCH</u> Module. Two Jumpers in Place. Do Not Remove unless <u>PATCH</u> Module is Used.
DS 1	Programming Display	Digital Display Illuminates only when Unit is in Program Configuration Model. See pages 21 and 22 for Programming Instructions.

Optional Input / Output Signal Configurations

JP 7	Panic Output	1 – jumper placed, center posts only- dry contact config. (Standard)
JP 6	CFG Enable	Placing a Jumper Across Pins enables Programming Configuration.
JP 3	Input Config.	Fuel Gas Detector
JP 4	Input Config.	LA Input/Fuel Gas Sensor (per Code Pos. 10 config.)
JP 10	Input Config.	Energy Management
JP 11	Input Config.	Alarm
CON 7	RTCC Output	Use by Factory Instructions only.
CON 6	Program Plug	Factory Use only. Do NOT make any connection to this Plug.

JP 3; JP 4; JP 10; JP 11 Jumper Configurations: Placing a jumper on the two center pins establishes the inputs as 24 vac. Placing two jumpers across the four pins allows for a dry-contact type input.

CAUTION: Care should be taken to verify proper jumper configuration prior to making any connections to input posts. Improper input configuration will result in damage to the circuit board and may void the warranty.

NOTE: “User Defined” Applications refer to integration with other types of facility control and/or monitoring systems where a 24 vac input control signal is required. Not intended for uses where operational power is required. When in question as to compatibility between the ISIMET Control System and desired integrated system, contact an ISIMET Sales Representative or the factory.

CAUTION: Do not terminate any 50 volt or greater at dry-contact outputs at Terminal 1. Maximum voltage input is 24-vac/vdc.

Figure 13 Terminal # 1 Pin Configuration

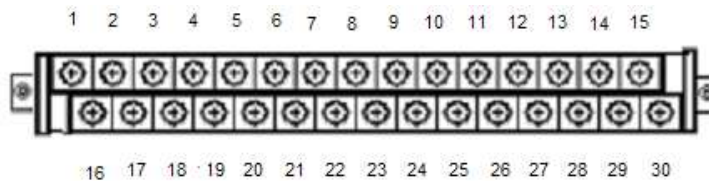

PINs		PINs	
1-2	LA Output (Dry-Contact)	16-17	Gas Detector (pcb Configurable)
3-4	LA Output (24-vac)	18-19	LA Input/Gas Sensor (pcb Configurable)
5-6	Alarm Output (Dry-Contact)	20-21	Alarm (pcb Configurable)
7-8	Alarm Output (24-vac)	22-23	LA Input 24-vac/dc Input
9-10	Panic Output (Dry-Contact)	24-25	Isolated Panic 24-vac/dc Input
11-12	Panic Output Configurable (Dry-Contact/24-vac)	26-27	EMS Input (pcb Configurable) 24-vac / 5-vdc
13	Remote Panic Input	28	VCC
14	Remote Panic Input / 24-vac	29	GND
15	24-vac com	30	24-vac Key Output

Fuel Gas Detector will effect circuit operation based on Table # 2: Circuit Function Criteria.

LA Output (Dry-Contact) used to interface with a single Companioned LA Unit.

LA Output (24-vac) used to interface with multiple Companioned LA Units.

24-vac Key Output used to reset an ISIMET Fuel Gas Detector.

Isolated Panic Input (PINs 24-25) allow for input from optional operator in order to advance unit to PANIC.

Remote Panic Input (PINs 13-14) allow for dry-contact interface from a Companioned LA Unit or Remote Panic.

LA Input (PINs 22-23) allow for 24-vac interface from a Companioned LA Unit

LA Input/Gas Sensor Input (PINs 18-19) allow for configurable interface from a Companioned LA Unit if Position 10 per Table 1 is set to '0'. Refer to LA Supplemental Companion Instructions Ver 9-1.

Make connections from appropriate Panic Output terminal at the LA Unit.

Instruction for Changing Programmable Configurations in Tables 1 and 2.

Note: Unit Should be idle, no Inputs or Output Active.

- To Enter Program Mode, place a Jumper on “CFG_Enable” JP06.
- Press the CFG_PGM Button to enter the Configuration Menu System.
LED17 “CONFIG” will Illuminate. Display will Illuminate W/ “P” and then @ “00”.
- Press the DOWN or UP Button to Select Configuration Position to Program.
- Press the CFG_PGM Button to enter Programming Mode for the Position.
- Display will show “d” momentarily followed then by the current setting.
- Press the DOWN or UP Button to Change Position Setting per Tables.
- Press the CFG_PGM Button to accept the Change.
Display will show “P” followed by current position.
- To Make More Changes Repeat Steps 3 through 7.
- When Finished, Remove the Jumper on “CFG_Enable” JP06
In order to return to Operate Mode.

Table # 1: Programmable Inputs

Setting	Position	Description	Options
RESET	1	Master Reset to Default Settings	0 = No 1 = Reset Defaults (See Next Page for Instructions)
EMS Input	2	Sets System Response to an Auto-Shutdown Signal	0 = No EMS 1 = EMS active ON 2 = EMS active OFF 3 = No EMS but First Key Time OUT
Key Reset	3	Sets Keying as a RESET Method	0 = RESET Button resets Panic, Alarm, etc 1 = RESET Button OR Keying
Alarm Output	4	1 Permits an Inverted or Momentary Output with Panic	0 = Standard 1 = Momentary Panic 2 = Inverted Panic & Alarm 3 = Invert Panic & Alarm W/O EMS 4 = Panic & Alarm 5 = Panic W/O Alarm
First Key Timing	5	In a Operation ON Cycle, after 1 st Keying all Circuits go OFF @ end of Cycle. Position 2 MUST be set to “3”.	0 = No Timing 4 = 4 Hr 6 = 6 Hr 8 = 8 Hr 10 = 10 Hr 12 = 12 Hr 16 = 16 Hr 20 = 20 Hr
Circuit Timing	6	After First Keying, With at least 1 Circuit ON, Circuits W/ “Timing OFF” =1 will go OFF	0 = No Timing 15 = 15 min 30 = 30 min 45 = 45 min 60 = 60 min 90 = 90 min 2 = 120 min 3 = 180 min 4 = 240 min
Panic Notify Delay	7	Panic Output will Operate W/O Delay OR After Selected Delay.	0 = No Delay 1 = 1 min 2 = 2 min 3 = 3 min 4 = 4 min 5 = 5 min
Gas Detector Panic Notify Delay	8	Gas Detected will Operate Panic Output Circuit	0 = No Effect 1 = 1 min 2 = 2 min 3 = 3 min 4 = 4 min 5 = 5 min 10 = 10 min
Exhaust Fan Timer	9	Exhaust Fan operated by Timer with or without panic	0 = No Timing 15 = 15 min 30 = 30 min 45 = 45 min 60 = 60 min
LA Input	10	Companion Input Mode @ Pins 18 & 19	0 = LA Companion Input 1 = Gas Detector Input for Cir 2 only 2 = LA Companion Input W/O EMS effect LA Output 3 = Gas Detector Input @ Cir 2 W/O EMS effect LA Output

CAUTION: Programming Codes are precisely set to specific criteria established at the time of product ordering. Field modifications should not jeopardize the safety features maintained by this code. Contact ISIMET or your local representative prior to changing any code settings. Failure to do so may void warranty and place the occupants of the facility in jeopardy of injury or loss of life.

Instruction for Resetting Unit to Factory Defaults

Note: Unit Should be idle, no Inputs or Output Active. A Jumper at “CFG_Enable” JP06 Must be in place.

1. Press the CFG_PGM Button to enter the Configuration Menu System.
LED17 “CONFIG” will Illuminate. Display will illuminate W/ “P” and then @ “00”.
2. Using the “UP” – “DOWN” Buttons, Select Position # 1.
3. Press the “CFG_PGM” Button.
4. Set Position # 1 to “1” and then press the “CFG_PGM” Button.
5. Remove the Jumper @ JP06.
6. The Factory Defaults are returned for all Programmable Settings.

Table # 2: Circuit Function Criteria

Circuit	Position	Description	Options
Cir #1	11	Fuel Gas Detector Effects Circuit Operation	0 = none 1 = yes
Cir # 1	12	Circuit Timing Effects Operation OFF	0 = no 1 = yes 2 = EMS-No effect on OFF
Cir #2	13	Fuel Gas Detector Effects Circuit Operation	0 = none 1 = yes
Cir # 2	14	Circuit Timing Effects Operation OFF	0 = no 1 = yes
Cir #3	15	Circuit is Standard or Fan	0 = Standard 1 = Fan
Cir #3	16	EMS Influence if Fan (for OFF W/Panic only)	0 = no 1 = yes
Cir #3	17	Fuel Gas Detector Effects Circuit Operation	0 = none 1 = yes
Cir # 3	18	Circuit Timing Effects Operation OFF (only if #15 = 1)	0 = no 1 = yes 2 = Fan Timer effects All OFFs
Cir # 3	19	Spare	
Cir #4	20	Circuit is Remote or Switched	0 = Remote 1 = Switch
Cir #4	21	Circuit is Standard or Fan	0 = Standard 1 = Fan
Cir #4	22	EMS Influence if Fan (for OFF W/Panic only)	0 = no 1 = yes
Cir #4	23	Fuel Gas Detector Effects Circuit Operation	0 = none 1 = yes
Cir # 4	24	Circuit Timing Effects Operation OFF (only if #20 = 1), #21 = 1	0 = no 1 = yes 2 = Fan Timer effects All OFFs
Cir # 4	25	Spare	
Cir #5	26	Circuit is Remote or Cir 3a	0 = none 1 = Remote 2 = Switch Cir 3a
Cir #5	27	If Circuit is Remote Standard or Fan	0 = Standard 1 = Fan
Cir #5	28	Spare	
Cir #5	29	Fuel Gas Detector Effects Circuit Operation	0 = none 1 = yes
Cir #5	30	If Remote Fan Circuit Timing Effects Operation OFF	0 = no 1 = yes (only if #31 = 1)
Cir #5	31	If Remote Fan If only active on Panic	0 = no 1 = yes
Cir # 5	32	Alarm Effects Circuit if Not Fan	0 = no 1 = yes OFF 2 = yes ON

Typical Installation Configurations:

The system is designed to operate all output circuits at 24 VAC. Typically, operating and control power for solenoids are provided through output circuits. Output circuits controlling electrical outlets are intended to provide control power only, and an interface relay is provided for that purpose. Consult installation instructions for the various companion enclosures provided with the unit.

Electrical – 120 VAC, 15 amp dedicated circuit, 14 AWG minimum

Natural Gas – 5 oz. max.

Domestic Water

Other Services: Refer to special instructions enclosed where applicable.

Output rating – 24 VAC 18 AWG minimum

CAUTION!

- ❑ Installation must comply with all local codes and ordinances.
- ❑ Connect only 120 VAC operating power to this equipment.
- ❑ Refer to Model Number Description for Model Designators.

Where controlled devices are not provided by *ISIMET*, output circuits should only provide control power and not operating power unless a project specific compliance certificate has been issued. Refer to compliance statements provided with the unit in cases where components are provided by others or contact *ISIMET* for additional information.

Figure 14

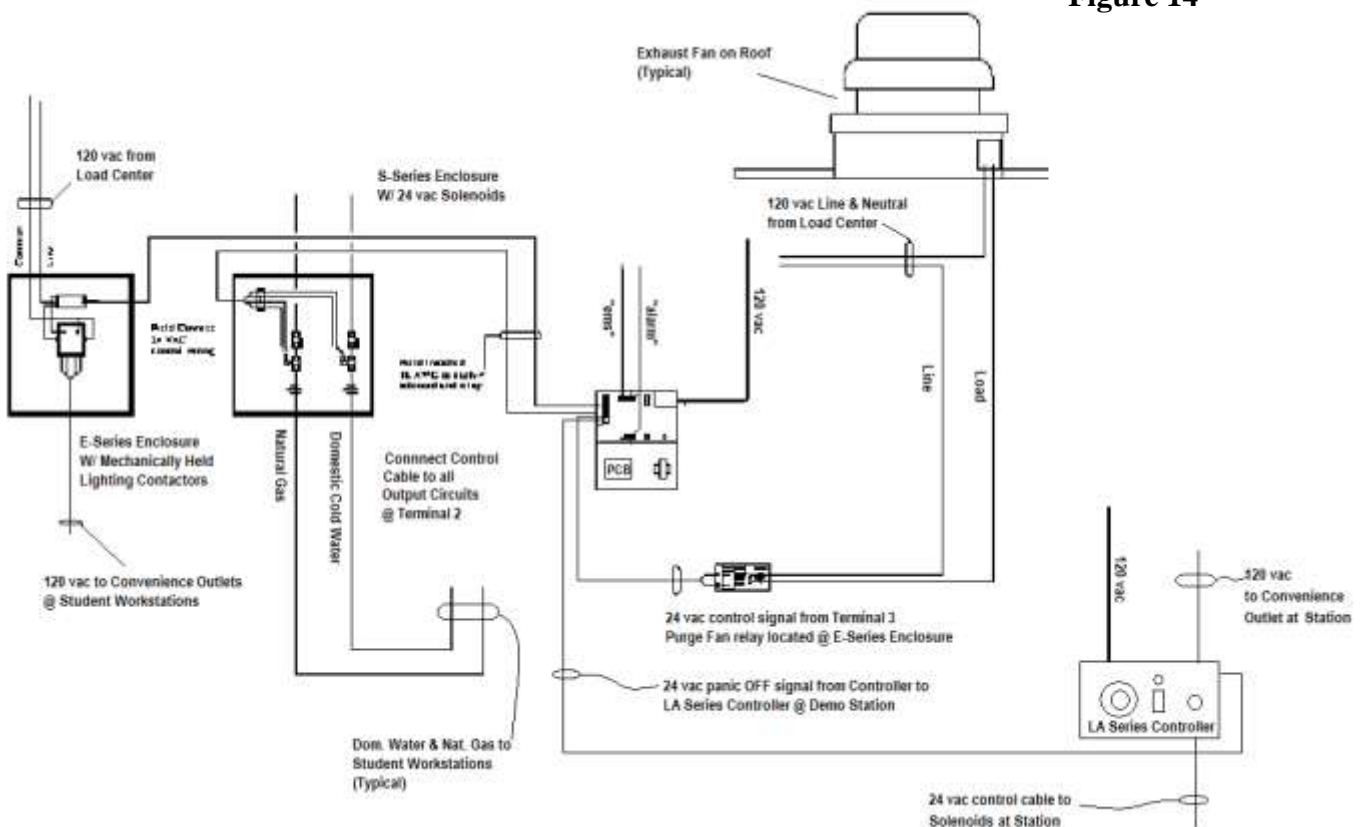

CAUTION:

ISIMET DOES NOT recommend that service to emergency and/or safety devices, such as emergency showers and eyewashes, be controlled by the Utility Controller System or Solenoids. Such devices are intended to operate independent of restrictive authority operation as is the case with the design of this unit. *ISIMET* makes available components for the monitoring of such safety devices. Please contact *ISIMET* regarding any questions regarding this type of application.

***ISIMET* believes that sole and local authority means that the primary operator or the instructors should have the sole authority to start and stop the utility services within the immediate area of use during normal usage. This should distinguish this type of operating environment from that where a single emergency shut-down device is located remotely from the areas of use. As an example, the *ISIMET* system is not specifically intended for use in applications where a master shut-down and re-instate device is located away from areas of normal use. *ISIMET's* opinion is that in such cases there is risk that the operator of the system during re-start may inadvertently activate utilities in an unoccupied area that is remote from the present occupancy, thus creating the risk of injury and/or fire where the utility is fuel gas.**

Additionally, the operation of emergency devices including emergency showers and eyewashes should not be integrated with this system for either activation or deactivation.



ISIMET/MAPA, LLC

**103 W. CJ Wise Parkway
PO Box 129
Naples, TX 75568**

**(903) 897-0737
Fax (903) 897-0740**

www.ISIMET.com

**Innovative Systems
Integrating
Mechanical and Electrical
Technology**